

PRODUCT NO.

SEE SHEET 4

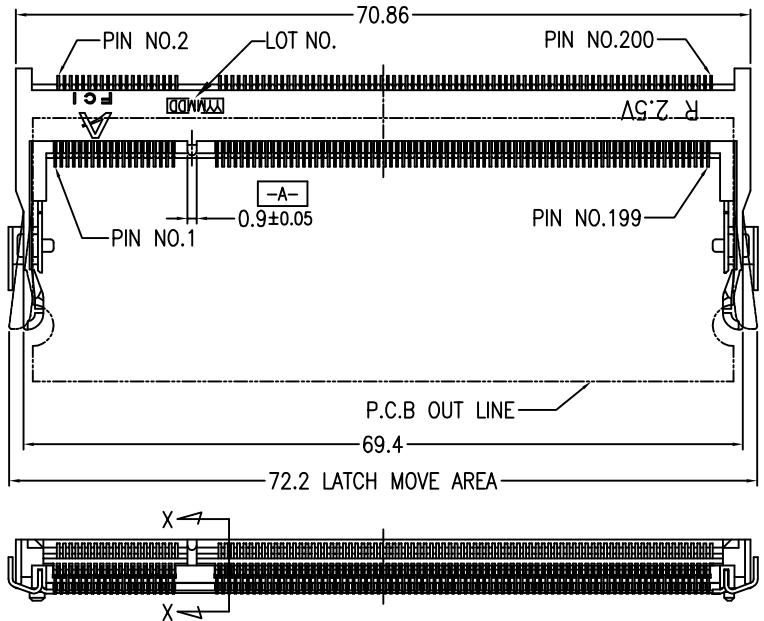

REVISIONS				
REV	DESCRIPTION	ECN	BY	DATE
J	REVISED	T05-0026	RC	02/04/05'
K	REVISED	0605-0388	K.W	10/13/05'
3	REVISED		HS	1/16/02
4	REVISED		HS	2/22/02
5	REVISED		HS	8/14/02
6	REVISED		HS	10/ 9/02
7	REVISED		HS	10/10/02
A	RELEASED	J20561	HS	10/17/02
B	ADDED NEW P/N	J20623	HS	12/13/02
C	ADDED DIMENSION	J03-0065	HS	2/10/03
D	ADDED -052T, -152T	J03-0243	M.H	6/2/03
E	REVISED	J03-0305	M.H	7/17/03
F	REVISED	J03-0434	M.H	11/10/03
G	REVISED	J04-0132	M.H	4/6/04
H	REVISED	T05-0022	R.C	01/27/05'

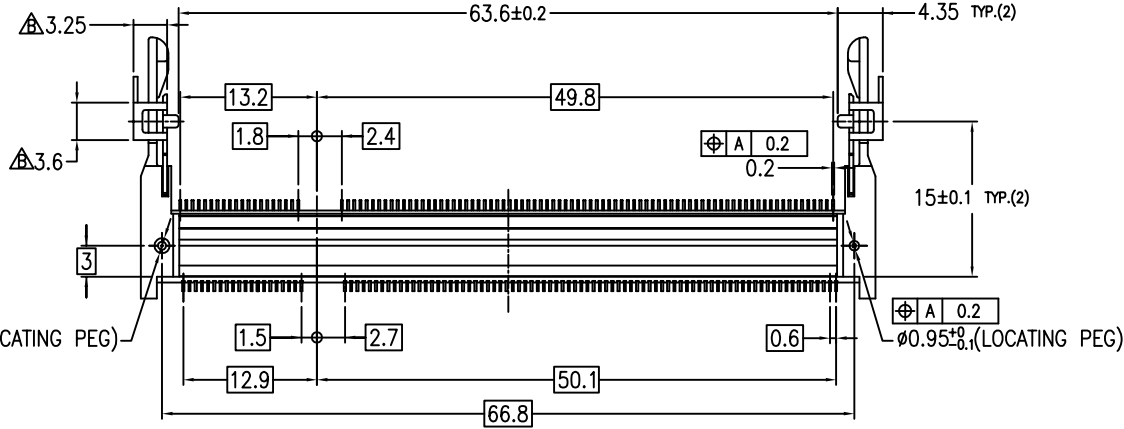
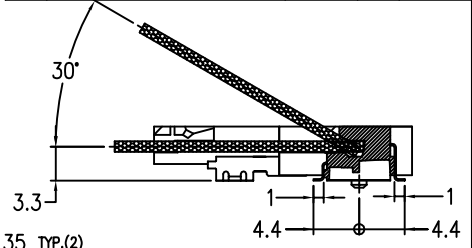

NOTE

- PRODUCT SPEC. : GS-12-195
- PACKAGING SPEC. : GS-14-786
- MATERIAL
  - HOUSING : LCP, UL94V-0, COLOR BLACK
  - CONTACT : PHOSPHOR BRONZE
  - HOLD DOWN : BRASS
- FINISH
  - TERMINAL : SEE TABLE  $\Delta$
  - HOLD DOWN : SEE TABLE  $\Delta$
- CO-PLANARITY : 0.1 MAX.(INCLUDE HOLD DOWN)
- THIS PRODUCT MEETS EUROPEAN UNION DIRECTIVES AND OTHER COUNTRY REGULATIONS AS DESCRIBED IN GS-22-008.
- THE HOUSING WILL WITHSTAND EXPOSURE TO 260° PEAK TEMPERATURE FOR 10 SECONDS IN A WAVE SOLDER APPLICATION.

SHEET INDEX	ISSUE SH NO.	K	F	E	J										
	1	2	3	4											
TOLERANCES UNLESS OTHERWISE SPECIFIED		MAT		DR		DATE		CUSTOMER COPY		TITLE					
±0.3		SEE NOTE		M.Hasegawa		10/04		THIRD ANGLE PROJ		DDR SO-DIMM 0.6 mm PITCH 200 POS. REVERSE TYPE ASS'Y					
LINEAR		FINISH		ENGR		10/04		UNIT		PRODUCT FAMILY		CODE JP			
		SEE NOTE		M.Hasegawa		MM		2/1		50UF SO-DIMM		K			
ANGLES				APPD		INCH		SCALE		SIZE		DWG. NO.		REV SHEET	
±2°								2/1		B		59355		10f4	



**FCI**

SCALE		SIZE		DWG. NO.		REV		SHEET	
2/1		B		59355		K		10f4	

DO NOT SCALE PRINT THIS INFORMATION IS CONFIDENTIAL AND IS DISCLOSED TO YOU ON CONDITION THAT NO FURTHER DISCLOSURE IS MADE BY YOU TO OTHER THAN FCI PERSONNEL WITHOUT WRITTEN AUTHORIZATION FROM FCI JAPAN K.K.

PRODUCT NO.

△ 59355-x52xx

REVISIONS

REV	DESCRIPTION	ECN	BY	DATE
1	SKETCHED		HS	9/27/'01
A	RELEASED	J20561	HS	10/17/'02
B	ADDED NEW P/N	J20623	HS	12/13/'02
C	ADDED -052T, -152T	J03-0243	M.H	6/2/'03
D	REVISED	J03-0305	M.H	7/17/'03
E	REVISED	J03-0434	M.H	11/10/'03
F	REVISED	DG05-0388	K.W	10/13/'05

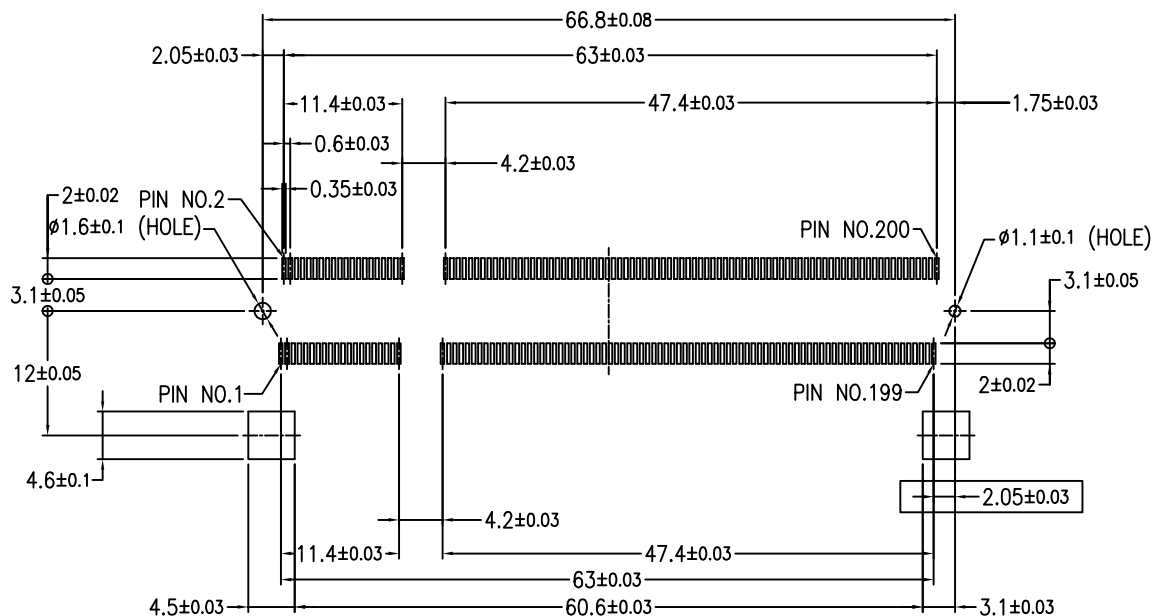

RECOMMENDED MOUNTING P.C.B LAYOUT



SHEET INDEX	ISSUE SH NO.												
TOLERANCES UNLESS OTHERWISE SPECIFIED		MAT	DR	DATE	CUSTOMER COPY	TITLE					CODE		
±0.3		—H—	M.Hasegawa	11/10/05		DDR SO-DIMM 0.6 mm PITCH 200 POS. REVERSE TYPE ASS'Y					JP		
LINEAR		FINISH	ENGR		THIRD ANGLE PROJ	PRODUCT FAMILY			SCALE	SIZE	DWG. NO.	REV	SHEET
		—H—	M.Hasegawa			50UF SO-DIMM			2/1	B		F	20F
ANGLES	±2°		CHK		UNIT	59355							

DO NOT SCALE PRINT THIS INFORMATION IS CONFIDENTIAL AND IS DISCLOSED TO YOU ON CONDITION THAT NO FURTHER DISCLOSURE IS MADE BY YOU TO OTHER THAN FCI PERSONNEL WITHOUT WRITTEN AUTHORIZATION FROM FCI JAPAN K.K.

DF-004A REV F

PRODUCT NO.

△ 59355-x52xx

REVISIONS

REV	DESCRIPTION	ECN	BY	DATE
1	SKETCHED		HS	9/27/01
A	RELEASED	J20561	HS	10/17/02
B	ADDED NEW P/N	J20623	HS	12/13/02
C	ADDED -052T, -152T	J03-0243	M.H	6/2/03
D	REVISED	J03-0305	M.H	7/17/03
E	REVISED	J03-0434	M.H	11/10/03

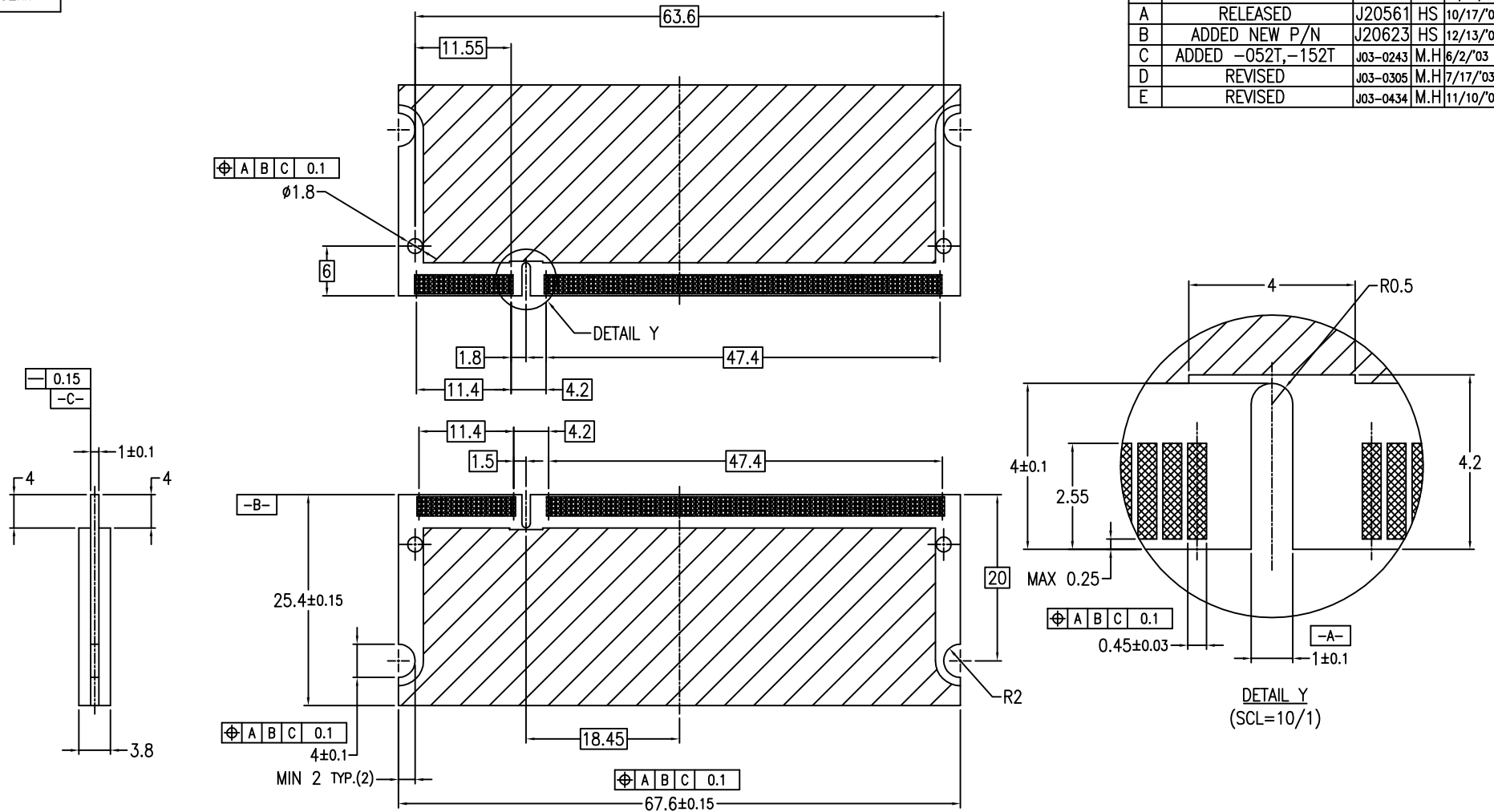

RECOMMENDED MODULE P.C.B LAYOUT

SHEET INDEX	ISSUE										
	SH NO.										
LINEAR	TOLERANCES UNLESS OTHERWISE SPECIFIED		MAT	DR	DATE	CUSTOMER COPY	TITLE DDR SO-DIMM 0.6 mm PITCH 200 POS. REVERSE TYPE ASS'Y				
	±0.3		—//—	<i>M. Hasegawa</i>	11/10/03						
ANGLES	±2°		FINISH	ENGR	DATE	THIRD ANGLE PROJ	PRODUCT FAMILY		CODE JP		
			—//—	<i>M. Hasegawa</i>	11/10/03		50UF SO-DIMM		30F		
UNIT							SCALE	SIZE	DWG. NO.	REV	SHEET
MM							2/1	B	59355	E	30F

DO NOT SCALE PRINT THIS INFORMATION IS CONFIDENTIAL AND IS DISCLOSED TO YOU ON CONDITION THAT NO FURTHER DISCLOSURE IS MADE BY YOU TO OTHER THAN FCI PERSONNEL WITHOUT WRITTEN AUTHORIZATION FROM FCI JAPAN K.K.

PRODUCT NO.	LOCATING PEG	TERMINAL CONTACT AREA FINISH	HOLD DOWN FINISH	SOLDER TAIL FINISH
59355-052FSLF	YES	Au FLASH	Pure Sn PLATING	Au FLASH PLATING
59355-152FSLF	NO			
59355-052TSLF	YES	Au 0.3um MIN.		
59355-152TSLF	NO			
59355-052ASLF	YES	Au 0.76um MIN.		
59355-152ASLF	NO			
59355-052FC	YES	Au FLASH	Sn-Pb PLATING	
59355-152FC	NO			
59355-052TC	YES	Au 0.3um MIN.		
59355-152TC	NO			
59355-052AC	YES	Au 0.76um MIN.		
59355-152AC	NO			
59355-252FSLF	YES	Au FLASH	Pure Sn PLATING	Pure Sn PLATING
59355-352FSLF	NO			
59355-252TSLF	YES	Au 0.3um MIN.		
59355-352TSLF	NO			
59355-252ASLF	YES	Au 0.76um MIN.		
59355-352ASLF	NO			
59355-252FC	YES	Au FLASH	Sn-Pb PLATING	
59355-352FC	NO			
59355-252TC	YES	Au 0.3um MIN.		
59355-352TC	NO			
59355-252AC	YES	Au 0.76um MIN.		
59355-352AC	NO			

PRODUCT NO.	LOCATING PEG	TERMINAL CONTACT AREA FINISH	HOLD DOWN FINISH	SOLDER TAIL FINISH
59355-452FS	YES	Au FLASH	Pure Sn PLATING	Sn-Pb PLATING
59355-552FS	NO			
59355-452TS	YES	Au 0.3um MIN.		
59355-552TS	NO			
59355-452AS	YES	Au 0.76um MIN.		
59355-552AS	NO			
59355-452FC	YES	Au FLASH	Sn-Pb PLATING	
59355-552FC	NO			
59355-452TC	YES	Au 0.3um MIN.		
59355-552TC	NO			
59355-452AC	YES	Au 0.76um MIN.		
59355-552AC	NO			

REVISIONS				
REV	DESCRIPTION	ECN	BY	DATE
A	SEE SHEET 4	J03-0434	M.H	11/10/03
B	REVISED	J04-0132	M.H	4/6/04
H	REVISED	T05-0022	R.C	01/27/05'
J	REVISED	T05-0026	R.C	02/04/05'

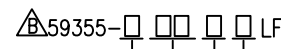

- <HOLD DOWN FINISH>
- S : Pure Sn
- C : Sn-Pb
- <CONTACT AREA FINISH>
- F : Au FLASH
- T : Au 0.3um MIN.
- A : Au 0.76um MIN.
- <TOTAL HEIGHT>
- 52 : 5.2mm
- <LOCATING PEG, SOLDER TAIL FINISH>
- 0 : YES, Au FLASH
- 1 : NO, Au FLASH
- 2 : YES, Pure Sn PLATING
- 3 : NO, Pure Sn PLATING
- 4 : YES, Sn-Pb PLATING
- 5 : NO, Sn-Pb PLATING

For Rohs OPTIONS:  
TAIL PLATING CODE MUST BE 0~3.  
HOLDOWN PLATING CODE MUST BE "S".  
"LF" CODE IS EXIST IN THE END.  
EX: 59355-252TSLF

FOR NOT Rohs COMPATIBLE:  
THIS "LF" CODE IS "BLANK".  
EX:59355-452TS

SHEET INDEX	ISSUE SH NO.											
TOLERANCES UNLESS OTHERWISE SPECIFIED		MAT SEE NOTE		DR	DATE	CUSTOMER COPY		TITLE				
±0.3				M.Hasegawa	4/17			DDR SO-DIMM 0.6 mm PITCH 200 POS. REVERSE TYPE ASS'Y				
LINEAR		FINISH SEE NOTE		ENGR		THIRD ANGLE PROJ		PRODUCT FAMILY		CODE JP		
				M.Hasegawa	4/17			50UF SO-DIMM				
ANGLES	±2°			CHK		UNIT		SCALE	SIZE	DWG. NO.	REV	SHEET
				APPD		MM INCH		2/1	B	59355	J	40F



DO NOT SCALE PRINT THIS INFORMATION IS CONFIDENTIAL AND IS DISCLOSED TO YOU ON CONDITION THAT NO FURTHER DISCLOSURE IS MADE BY YOU TO OTHER THAN FCI PERSONNEL WITHOUT WRITTEN AUTHORIZATION FROM FCI JAPAN K.K.